

---

## IMAGENEX MODEL 965A MULTIBEAM IMAGING SONAR

### APPLICATIONS:

- ROV, AUV, & UUV
- Offshore Oil & Gas
- Sunken Timber Recovery
- Diving Support
- Surveying
- Search & Recovery
- Inspection
- Underwater Archaeology
- Scientific Research
- Harbour Surveillance

### FEATURES:

- High speed
- Ethernet (10/100 Mbps)
- Programmable
- Simple set-up and installation
- 5 m to 100 m range scales
- Integrated Video Capture and Display
- Raw data available to user

The Imagenex Model 965A is an advanced, high-speed, high-resolution, multibeam imaging sonar system that has been designed to provide simple, reliable, and accurate representation of underwater images.

The system consists of an underwater sonar head connected by Ethernet to a Windows™ based computer.



<b>HARDWARE SPECIFICATIONS:</b>	
<b>FREQUENCY</b>	675 kHz
<b>TRANSDUCER BEAM WIDTH (nominal)</b>	Receive: 120° (horizontal) x 20° (vertical) Transmit: 120° (horizontal) x 20° (vertical)
<b>EFFECTIVE HORIZONTAL BEAM WIDTH</b>	1.5°
<b>BEAMS*</b>	120, 240, 480
<b>RANGE RESOLUTION</b>	0.2% of range
<b>MIN. DETECTABLE RANGE</b>	0.5 m
<b>MAX. OPERATING DEPTH</b>	1000 m and 2000 m available
<b>FRAME RATE</b>	Up to 40 fps
<b>INTERFACE TO PC</b>	Standard: 10/100 Mbps Ethernet (10 BASE-T or 100 BASE-TX) using TCP/IP
<b>MAX. CABLE LENGTH</b>	Standard: 100 m on CAT5e
<b>CONNECTOR</b>	End mounted, 8 conductor, wet mateable (Subconn MCBH8M-AS)
<b>POWER SUPPLY</b>	22 – 32 VDC at less than 25 Watts
<b>DIMENSIONS</b>	See drawing
<b>WEIGHT: In Air</b>	1000 m unit: 1.5 kg (3.3 lbs) 2000 m unit: TBA
<b>In Water</b>	1000 m unit: 0.045 kg (0.01 lbs) 2000 m unit: TBA
<b>MATERIALS</b>	<b>1000 m unit:</b> 6061-T6 Aluminum, Epoxy, PVC, Aluminum connector <b>2000 m unit:</b> Titanium, Epoxy, PVC, Titanium connector
<b>FINISH</b>	Anodize

\*Data is acquired at full resolution every shot: processing the data for screen display on a PC can slow the system at highest number of beams. 120 beam mode is recommended for real time data acquisition. The data can then be played back at highest resolution (480 beam).

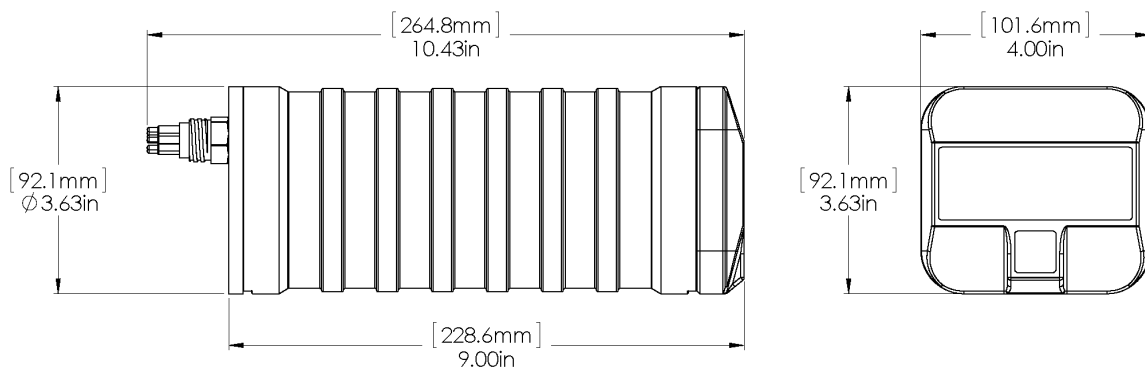

<b>SOFTWARE SPECIFICATIONS:</b>	<b>Win965A.exe</b>
<b>WINDOWS™ OPERATING SYSTEM</b>	Windows™ XP, Vista, 7, 8, 10
<b>DISPLAY MODES</b>	Sector, Linear, Perspective, Profile, Beam Test
<b>PERSISTENCE (TRAIL)</b>	1 – 300 seconds
<b>RANGE SCALES</b>	5 m - 100 m
<b>SECTOR SIZES</b>	30°, 60°, 90°, 120°
<b>FILE FORMAT</b>	(filename).IGX
<b>RECOMMENDED MINIMUM COMPUTER REQUIREMENTS:</b>	2 GHz Pentium 4 256 MB RAM 20 GB Hard Disk 1024 x 768 screen resolution

<b>ORDERING INFORMATION:</b>		
<b>1000 m UNIT</b>	Standard	965A-000-200
<b>2000 m UNIT</b>	Standard	965A-000-201
Right Angle Connector	Option	-010
IP Address*	Option	-020

\*Note: Standard IP Address is 192.168.0.2  
A different IP Address may be specified upon ordering.

Product and company names listed are trademarks or trade names of their respective companies.