



IMAGENEX MODEL 881A

DIGITAL MULTI-FREQUENCY PROFILING SONAR w/PRH SENSOR & DEPLOYMENT CONE

APPLICATIONS:

- Profiling
- Offshore Oil & Gas
- Surveying
- Dam Face Inspection
- Underwater Archaeology
- Scientific Research
- Drop sonar
- Borehole Inspection

FEATURES:

- Programmable
- Multi-frequency
- High performance
- Lower cost
- Low power
- Simple set-up and installation
- Digital telemetry
- 1 to 100 m operation (full scale)
- Built-in orientation module (PRH)
- Communication format available to user



HARDWARE SPECIFICATIONS:	
FREQUENCY	675 kHz -Other frequencies can be selected through programmable software configurations (Tunable from 600 kHz to 1 MHz in 5 kHz steps)
TRANSDUCER	Profiling type, fluid compensated
TRANSDUCER BEAM WIDTH	600 kHz: 2.4° 675 kHz: 2.1° 1 MHz: 1.4°
RANGE RESOLUTION	1 m – 4 m: 2 mm (0.08") 5 m & up: 10 mm (0.4")
MIN. DETECTABLE RANGE	150 mm (6")
ORIENTATION MODULE (accuracies):	
PITCH & ROLL	± 0.1° typical
HEADING	± 1.0° typical
MAX. OPERATING DEPTH	1000 m and 3000m available
MAX. CABLE LENGTH	1000 m on typical twisted shielded pair (RS-485)
INTERFACE	RS-485 serial interface @ 115.2 kbps (or optional RS-232)
CONNECTOR	End mounted, four conductor, wet mateable (Subconn MCBH4M-AS)
POWER SUPPLY	45 – 130 VDC at less than 5 Watts
DIMENSIONS (for both depth ratings)	See drawing
WEIGHT: In Air	1000 m unit: ~2.7 kg (~6 lbs) 3000 m unit: TBA
In Water	1000 m unit: ~1.1 kg (~2.5 lbs) 3000 m unit: TBA
MATERIALS	1000 m unit: 6061-T6 Aluminum, PVC & Polyurethane 3000 m unit: Titanium, Polyurethane, PVC & 300 series stainless steel
FINISH	Hard Anodize

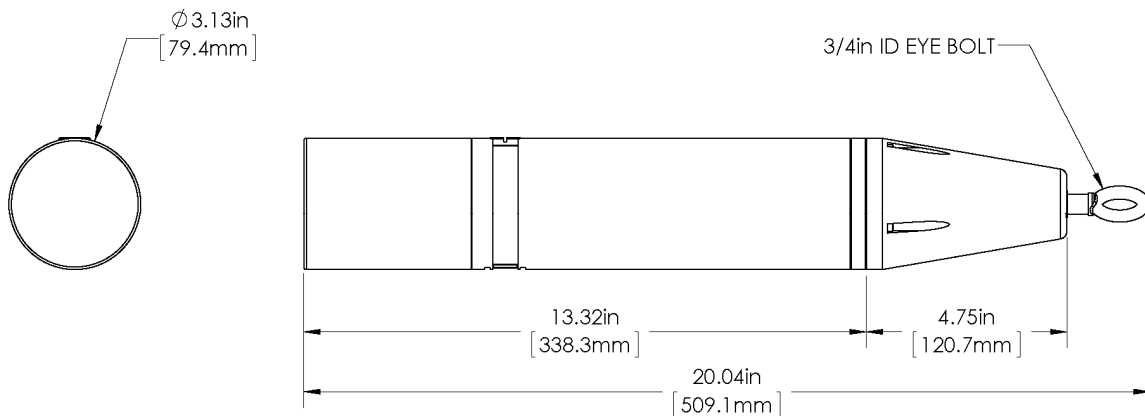

SOFTWARE SPECIFICATIONS:	Win881A.exe
WINDOWS™ OPERATING SYSTEM	Windows™ XP, Vista, 7, 8, 10
MODES	Side Scan, Polar, and Sector
RANGE SCALES	1 m, 2 m, 3 m, 4 m, 5 m, 10 m, 20 m, 30 m, 40 m, 50 m, 60 m, 80 m, 100 m
TRAIN ANGLES	Continuous rotation, 3° increments
SECTOR SIZE: SECTOR MODE POLAR MODE	0° – 180°, 3° increments 0° – 357°, 3° increments, or Continuous rotation
STEP SIZES	Slow (0.3°), Medium (0.6°), Fast (0.9°), Faster (1.2°), Fastest (2.4°)
GRID TYPES	Polar and rectangular
FILE FORMAT	(filename).81a
RECOMMENDED MINIMUM COMPUTER REQUIREMENTS:	100 MHz Pentium 16 MB RAM 1 GB Hard Disk 800 x 600 x 256 colour graphics

ORDERING INFORMATION:		
1000 m UNIT	Standard	881-000-420
3000 m UNIT	Standard	881-000-421
Pitch, Roll & Heading Sensor	Option (included)	-030
Deployment Cone	Option (included)	-052

Product and company names listed are trademarks or trade names of their respective companies.