

IMAGENEX MODEL 872 “YELLOWFIN” SIDESCAN SONAR

APPLICATIONS:

- Underwater Archaeology
- Sunken Timber Recovery
- Search & Recovery
- Surveying
- Law Enforcement Work
- Scientific Research
- Environmental Survey

FEATURES:

- Triple frequency
- High resolution 1000 data points per side
- 300 m depth rating
- Up to 400 m (1300') total coverage
- 23 m (75') tow cable included
- LAN compatible
- Built-in track plotter
- Built-in internal GPS receiver
- Record to .XTF in real-time

The Imagenex Model 872 “YellowFin” is a full-featured dual channel, high resolution, sidescan sonar. The YellowFin is an affordable, very user friendly system that incorporates a high speed Ethernet connection to your Windows™ based laptop or desktop PC. Integrated power and a built-in differential-ready GPS receiver complete this fantastic system. Zoom windows are available for target investigation without interrupting real-time data acquisition. Data is displayed in real-time, with or without speed correction, in 9 user selectable colour tables.



UNDERWATER HARDWARE SPECIFICATIONS:	
FREQUENCY	260 kHz / 330 kHz / 800 kHz nominal
TRANSDUCER	One transducer per side, tilted down 20°
TRANSDUCER BEAM WIDTH	260 kHz: 2.2° x 75° 330 kHz: 1.8° x 60° 800 kHz: 0.7° x 30°
RANGE RESOLUTION	Range scale ÷ 1000
MAX. OPERATING DEPTH	300 m (~1000')
MAX. CABLE LENGTH	600 m (~2000')
INTERFACE	Analog telemetry
CONNECTOR	Wet mateable (Subconn MCBH4M-AS)
POWER SUPPLY	40 – 55 VDC at less than 3 Watts, supplied from Surface Interface Box
DIMENSIONS	114 mm (4.5") diameter x 833 mm (32.8") length
WEIGHT:	5.4 kg (12 lbs) not including ballast
In Water	
BALLAST	Standard diver belt weights (readily available at dive shops)
MATERIALS	Polyurethane & 6061-T6 Aluminum
FINISH	Hard anodized

SURFACE INTERFACE BOX HARDWARE SPECIFICATIONS:	
INTERFACE TO PC	10 Mbps Ethernet
INTERFACE TO SONAR HEAD	FSK analog telemetry
CABLE CONNECTOR	5-pin MS (female)
SONAR HEAD POWER SUPPLY OUTPUT	48 VDC
DIFFERENTIAL CAPABLE GPS	Built-in
DIMENSIONS	31 cm (12.2") length x 26 cm (10.2") width x 8.7 cm (3.4") height
WEIGHT	0.9 kg (2 lbs)
MATERIALS	Aluminum
FINISH	Powder Coated
POWER REQUIREMENT	110 / 220 VAC 50 / 60 Hz, 0.1 Amp

SOFTWARE SPECIFICATIONS:	YellowFin.exe
WINDOWS™ OPERATING SYSTEM	Windows™ XP, Vista, 7, 8, 10
ZOOM MODES	1x, 2x, 3x, 4x, and 5x dynamically moveable
RANGE SCALES	10 m, 20 m, 30 m, 40 m, 50 m, 60 m, 80 m, 100 m, 125 m, 150 m, and 200 m
FILE FORMAT	(filename).872, (filename).XTF
GPS INPUT (4800, N, 8, 1) NMEA 0183 FORMATS:	GLL and VTG; GGA and VTG; RMC
RECOMMENDED MINIMUM COMPUTER REQUIREMENTS:	800 MHz Pentium 3 256 MB RAM 2 GB Hard Disk 1024 x 768 x 256 colour graphics

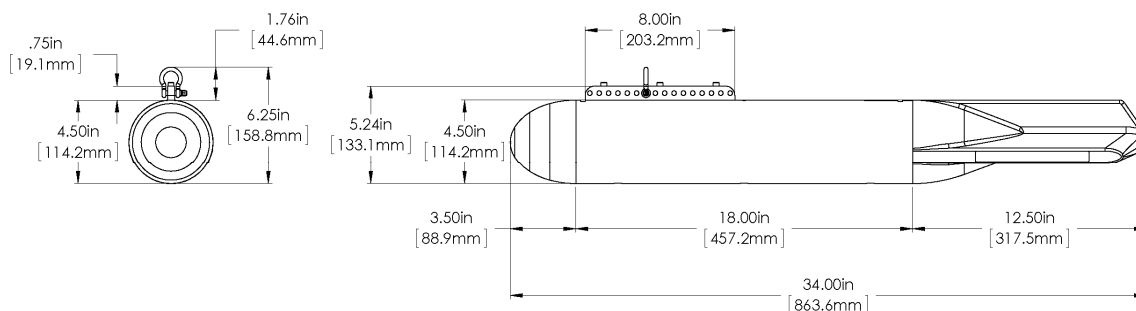

ORDERING INFORMATION:		
300 m unit w / 23 m tow cable	Standard	872-000-150
Surface Interface Box	Standard	872-000-002
60 m (200') Sidescan tow cable	Option	-021
100 m (330') Sidescan tow cable	Option	-033

Product and company names listed are trademarks or trade names of their respective companies.