



**DT101xi**  
445-105 MARCH 2018

**IMAGENEX MODEL DT101xi  
MULTIBEAM PROFILING SONAR  
with Optional Internally Integrated  
Motion Reference Unit  
& Sound Velocity Sensor**



The new DT101xi Multibeam Profiling Sonar (i.e. Multibeam Echo Sounder) is a single instrument integrating the sonar, motion reference unit (MRU), and sound velocity sensor into one sleek and compact unit. The DT101xi requires only one cable for operating all three sensors and is a portable solution for any survey. Compatible with the DT100 SIR (Sensor Interface Relay) power supply/timing box, simply connecting a dual antenna GNSS/GPS receiver is all that is required to perform bathymetric surveys.

Patent Pending

<b>HARDWARE SPECIFICATIONS:</b>	
<b>FREQUENCY</b>	240 kHz
<b>SWATH WIDTH (nominal beam geometry)</b>	Transmit: 120° x 3° Receive: 120° x 3°
<b>EFFECTIVE BEAM WIDTHS</b>	Narrow: 0.75° Medium: 1.5° Wide: 3°
<b>NUMBER OF BEAMS</b>	Default: 480 Selectable: 240, 120
<b>RANGE RESOLUTION: SCREEN OUTPUT</b>	0.1% of range 0.01% of range
<b>RANGE</b>	75 m (246') water depth 150 m (492') slant range
<b>MIN. DETECTABLE RANGE</b>	0.5 m (1.6') below transducer
<b>MOTION REFERENCE UNIT</b> Pitch and Roll Accuracy: Heave:	Internally mounted OEM version 0.04° 5 cm or 5% (whichever is greater)
<b>SOUND VELOCITY SENSOR</b>	Internally mounted OEM version of AML Micro•X 1400 m/s to 1600 m/s +/- 0.025 m/s
<b>MAX. OPERATING DEPTH (Submersion depth)</b>	300 m (984') Contact Imagenex if a greater depth rating is required
<b>INTERFACE TO PC</b>	Ethernet (100 Mbps) using TCP/IP
<b>MAX. CABLE LENGTH</b>	100 m (328') on CAT5-e, longer cable runs possible with additional hardware
<b>CONNECTOR</b>	Underwater wet-mateable 8 conductor
<b>POWER SUPPLY (sonar head only)</b>	22 - 50 VDC at less than 10 Watts
<b>DIMENSIONS</b>	306 mm (12.05") L x 118 mm (4.63") H x 94 mm (3.68") W
<b>WEIGHT: In Air</b>	4.2 kg (9.5 lbs)
<b>In Water</b>	1.9 kg (4.2 lbs)
<b>MATERIALS</b>	Polyoxymethylene (i.e. Delrin), Titanium, PVC, Titanium connector
<b>POWER SUPPLY/ TIMING BOX:</b>  <b>DT100 Sensor Interface Relay (DT100 SIR)</b>	2 port Ethernet switch (DT101xi PC and Survey PC) Interfaces to: DT101xi GNSS (GPS) Gyro / Heading Sensor 100 – 240 VAC or 12 – 36 VDC input range Dimensions: 394 mm (15.5") x 314 mm (12.4") x 92 mm (3.6")
<b>MAX. PING RATE</b>	20 Hz

<b>SOFTWARE SPECIFICATIONS:</b>	<b>DT101Xi_SIR.exe</b>
<b>WINDOWS™ OPERATING SYSTEM</b>	Windows™ XP, Vista, 7, 8, 10
<b>DISPLAY MODES</b>	Sector, Linear, Perspective, Profile, Beam Test
<b>PERSISTENCE (TRAIL)</b>	1 – 300 seconds
<b>RANGE SCALES</b>	5 m, 10 m, 20 m, 30 m, 40 m, 50 m, 60 m, 80 m, 100 m, 150 m
<b>SECTOR SIZES</b>	30°, 60°, 90°, 120°
<b>FILE FORMAT: RAW DATA PROFILE POINT</b>	(filename).D1R (filename).D1P
<b>RECOMMENDED MINIMUM COMPUTER REQUIREMENTS:</b>	2 GHz Pentium 4 256 MB RAM 20 GB Hard Disk 1024 x 768 screen resolution

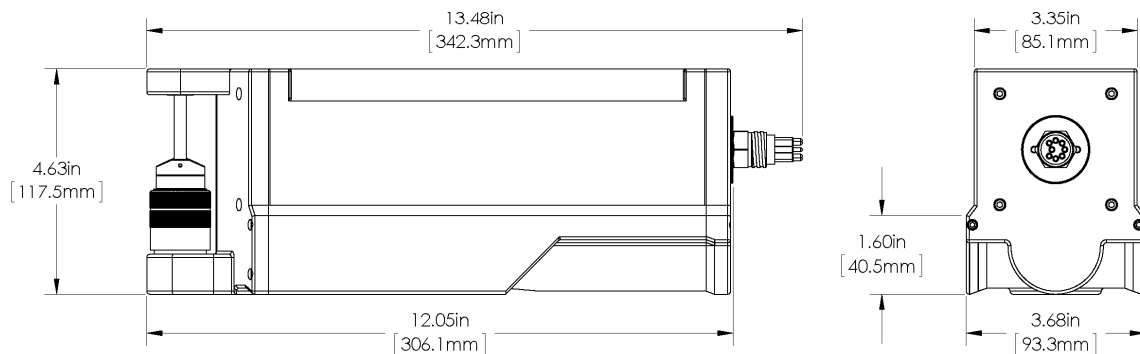
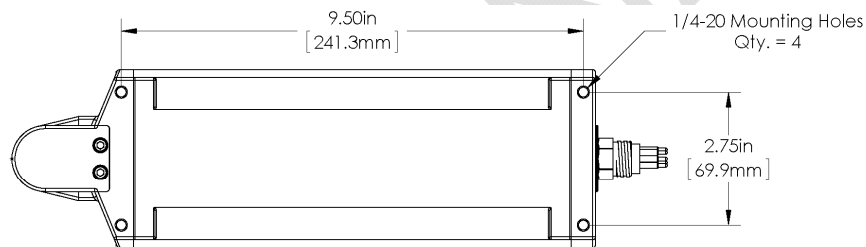

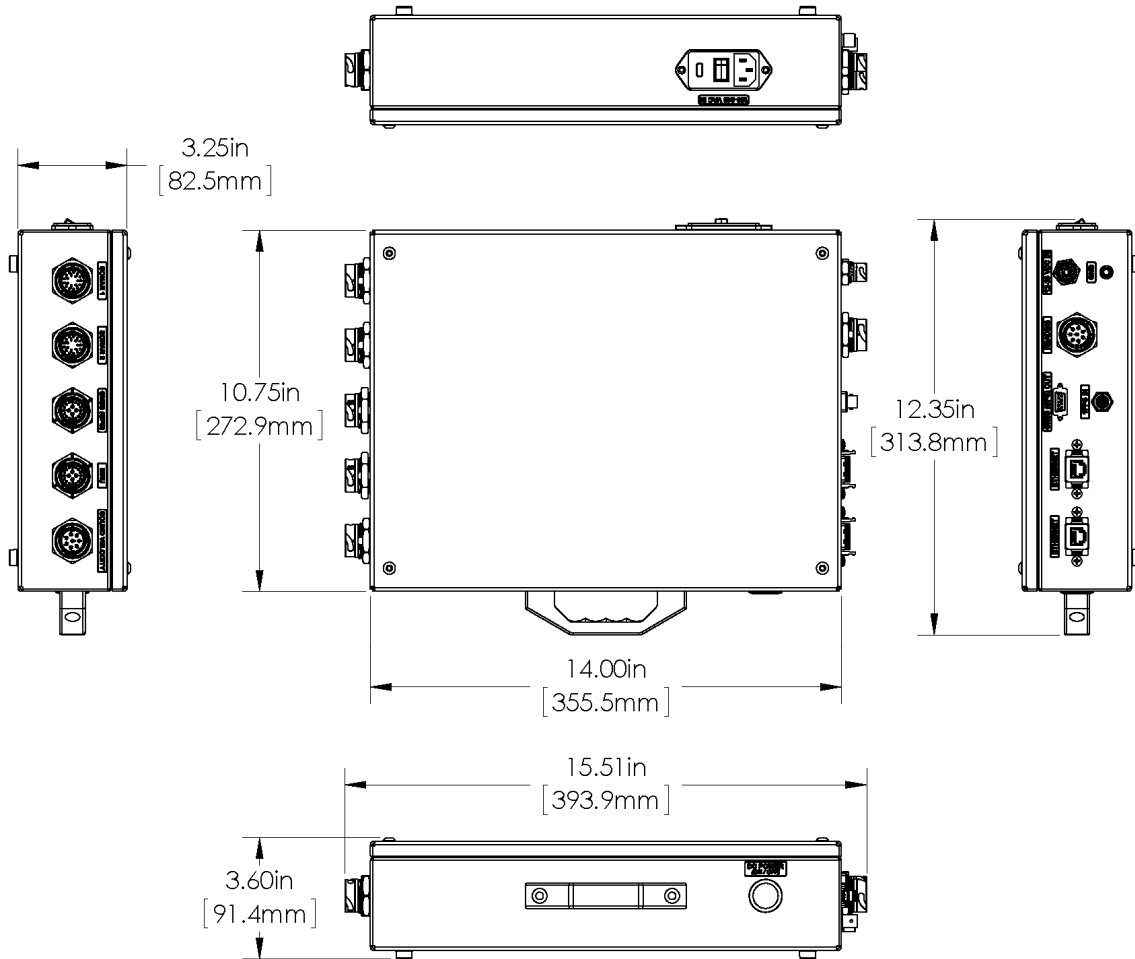

<b>ORDERING INFORMATION:</b>		
<b>300 m UNIT</b>	Standard	838-000-101
<b>Sensor Interface Relay box (DT100 SIR)</b>	Standard	837-000-007
IP Address*	Option	-020

\*Note: Standard IP Address is 192.168.0.2  
 A different IP Address may be specified upon ordering.

Product and company names listed are trademarks or trade names of their respective companies.