



837B Delta T 6000 m Profiling  
445-098 DECEMBER 2015-REVISED MAY 2017

## IMAGENEX MODEL 837B “Delta T” 6000 m MULTIBEAM PROFILING SONAR

### APPLICATIONS:

- ROV, AUV, & UUV
- Offshore Oil & Gas
- Sunken Timber Recovery
- Diving Support
- Surveying
- Search & Recovery
- Inspection
- Underwater Archaeology
- Scientific Research

### FEATURES:

- Programmable
- High speed
- High performance
- Lower cost
- Low power
- Simple set-up and installation
- Ethernet
- 5 m to 100 m range scales
- Integrated Video Capture and Display
- Built in GPS Track Plotter

The Imagenex Model 837B “Delta T” is a multiple receiver sonar system designed to provide video-like imaging with all the advantages of underwater sonar. Innovative digital signal processing is used to optimize data usage from all channels to achieve the best possible resolution at every point in the field of view. Recent advances in computing power have made it possible to transfer and process this data at resolutions equal to computer monitor resolution, and with image frame rates of better than 20 frames per second!

The Delta T system has been designed from the ground up with the most advanced, high accuracy, low power electronic components available to provide breakthroughs in system power consumption, package size, and price. This advanced electronics package has built in flexibility and programmability to accommodate a wide range of transducer arrays. Thus, the Delta T is the first in a family of new technology products which will have imaging and profiling capabilities to suit your underwater application. Imagenex sonars: advancing underwater imaging capability for the everyday user.



Patent Pending

<b>HARDWARE SPECIFICATIONS:</b>	
<b>FREQUENCY</b>	260 kHz
<b>TRANSDUCER BEAM WIDTH (nominal)</b>	Receive: 120° x 3° Transmit: 120° x 3°
<b>EFFECTIVE BEAM WIDTH</b>	3°, 1.5°, 0.75°
<b>BEAMS*</b>	120, 240, 480
<b>RANGE RESOLUTION: SCREEN OUTPUT</b>	0.2% of range 0.02% of range
<b>MIN. DETECTABLE RANGE</b>	0.5 m
<b>MAX. OPERATING DEPTH</b>	6000 m
<b>FRAME RATE</b>	Up to 20 fps
<b>INTERFACE TO PC</b>	10/100 Mbps Ethernet Bit rate may vary if an Ethernet extender is in use.
<b>MAX. CABLE LENGTH</b>	Standard: 100 m on CAT5e Cable length may be increased up to ~9000 m using an Ethernet extender. Please enquire for more information.
<b>CONNECTOR</b>	End mounted, 8 conductor, wet mateable (Subconn MCBH8M-Ti)
<b>POWER SUPPLY</b>	22 – 32 VDC at less than 5 Watts
<b>DIMENSIONS</b>	See drawing
<b>WEIGHT: In Air</b>	~5 kg (~11 lbs)
<b>In Water</b>	~2.9 kg (~6.3 lbs)
<b>MATERIALS</b>	6AL4V Titanium, Epoxy, PVC, Titanium connector

\* Data is acquired at full resolution every shot: processing the data for screen display on a PC can slow the system at highest number of beams. 120 beam mode is recommended for real time data acquisition. The data can then be played back at highest resolution (480 beam).

<b>SOFTWARE SPECIFICATIONS:</b>	<b>DeltaT.exe</b>
<b>WINDOWS™ OPERATING SYSTEM</b>	Windows™ XP, Vista, 7, 8, 10
<b>DISPLAY MODES</b>	Sector, Linear, Perspective, Profile, Beam Test
<b>PERSISTENCE (TRAIL)</b>	1 – 300 seconds
<b>RANGE SCALES</b>	5 m, 10 m, 20 m, 30 m, 40 m, 50 m, 60 m, 80 m, 100 m
<b>SECTOR SIZES</b>	30°, 60°, 90°, 120°
<b>IP ADDRESS</b>	User programmable (Default is 192.168.0.2)
<b>FILE FORMAT: RAW DATA PROFILE POINT</b>	(filename).837 (filename).83P
<b>RECOMMENDED MINIMUM COMPUTER REQUIREMENTS:</b>	2 GHz Pentium 4 256 MB RAM 20 GB Hard Disk 1024 x 768 screen resolution

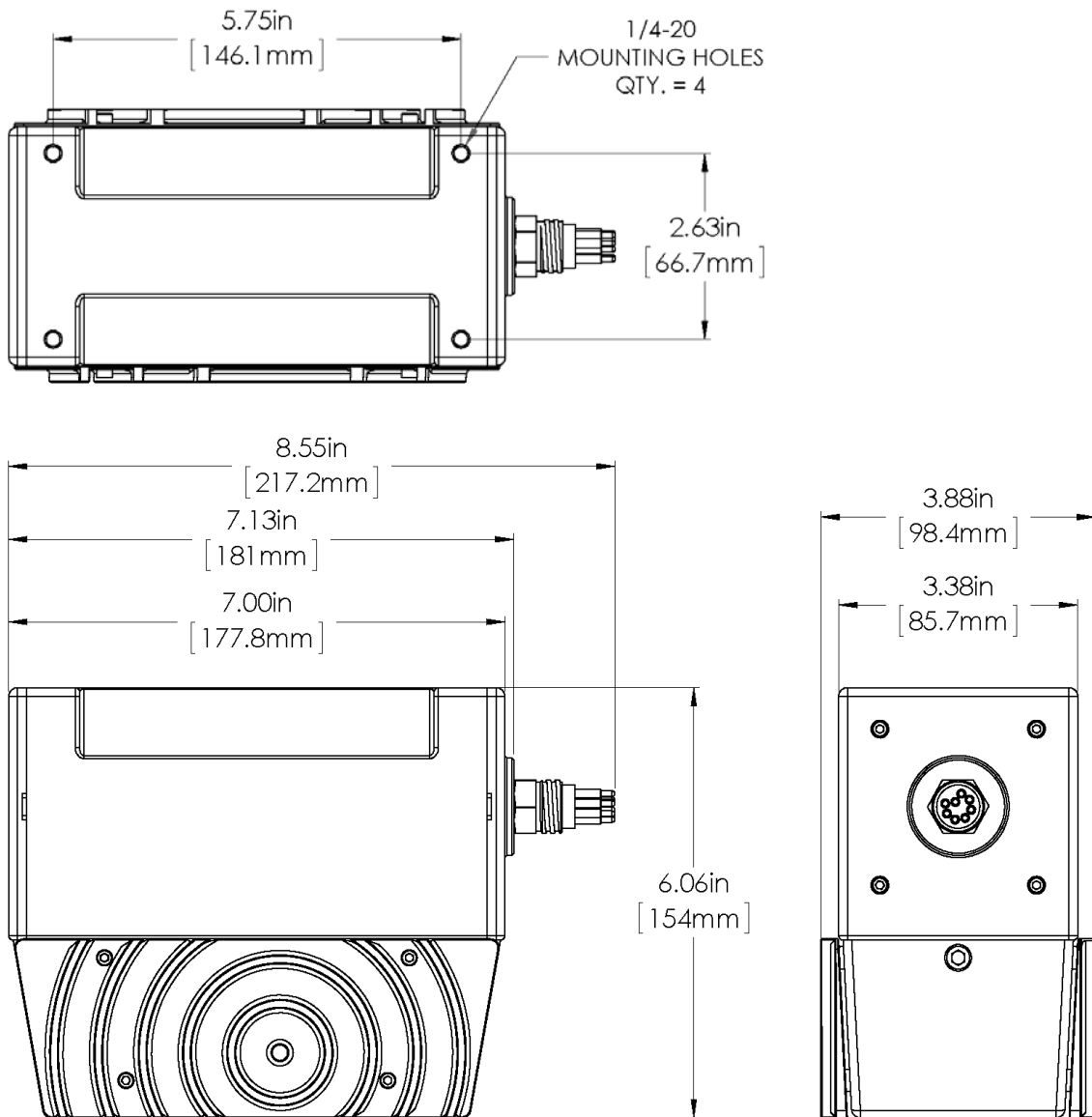

**ORDERING INFORMATION:**

<b>6000 m UNIT in Titanium</b>	Standard	837B-000-437
External Trigger	Option	-023
Dual Head Software	Option	-024

Product and company names listed are trademarks or trade names of their respective companies.